

Analog amplifier

RE 29926/10.06
Replaces: 07.03

1/8

Type VT 3006

Component Series 3X

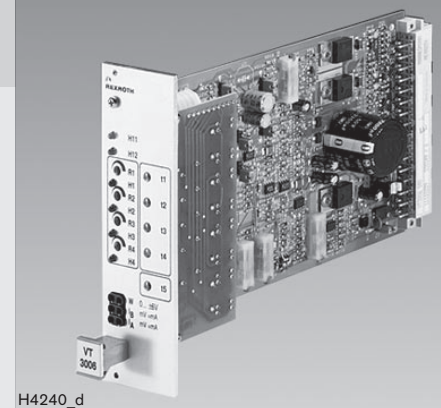

Table of contents

Contents	Page
Features	1
Ordering code	2
Functional Description	2 and 3
Block circuit / pin allocation	4
Technical Data	5
Output curve	6
Indicator / Adjustment elements	6
Unit dimension	7
Engineering notes / maintenance instructions / supplementary information	7

Features

- Suitable for the control of pilot operated proportional directional valves (type .WRZ, up to component series 6X) and direct operated proportional pressure valves (type DBEP6 and 3DREP6, each component series 1X) without electrical position feedback
- Four command values adjustable with potentiometers
- Four command value call-ups with LED display
- Differential input
- Step function generator
- Ramp generator with five ramp times
- Two pulsed current output stages
- Polarity protection for the voltage supply

Card holder:

- Type VT 3002-2X/32, see RE 29928
- Single card holder without power pack

Power pack:

- Type VT-NE30-2X, see RE 29929
- Compact power pack 115/230 VAC → 24 VDC, 108 W

Note:

When supplied the amplifiers have a ramp time of 5 s (setting of the ramp time of 1 s see page 5).

Ordering code

VT 3006 -3X/ *

Amplifier for prop. directional valves (type .WRZ, up to component series 6X) and prop. pressure valves (type DBEP6 and 3DREP6, each component series 1X)

Component series 30 to 39
(30 to 39: unchanged technical data and pin allocation)

= 3X

Further details in clear text

Functional Description

With the command value inputs 1 to 4 command values can be called up [1] by operating the corresponding relays (K1 to K4). The command value voltage is either given directly through the controlled voltages ± 9 V of the power supply [10] or via an external command value potentiometer. For this inputs ± 9 V $\triangleq \pm 100\%$ ¹⁾ is valid. If these four command value inputs are directly connected to the controlled voltages ± 9 V four different command values can be set at the potentiometers „R1“ to „R4“. When using external command value potentiometers at these inputs the internal potentiometers also function as weakeners or limiters when these are not set to maximum.

External command value potentiometer

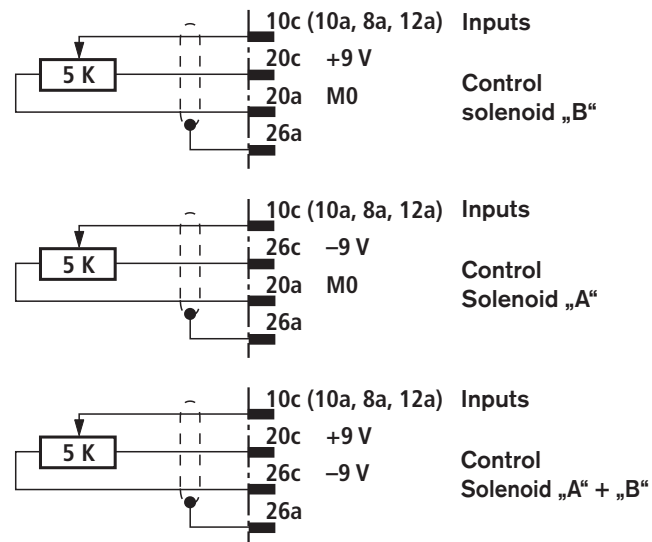

Which command value is momentarily called up is indicated by the LEDs „H1“ to „H4“. If more than one command value is called up simultaneously the input with the highest number has priority. Example: If command value 1 and command value 3 are activated simultaneously the command value 3 becomes effective

A further output of the card provides a supply voltage for the command value call-ups which can be switched over from +9 V to -9 V with the relay K6 ¹⁾.

All relays on the card are switched with 24 VDC (smoothed). Additionally, the direct command value input 5 is available for the input voltage 0 to ± 6 V. Valid is ± 6 V $\triangleq \pm 100\%$ ¹⁾.

The command value input 6 is a differential input (0 to ± 10 V). If the command value is presented by a separate electronics with a different reference potential this input must be used. When switching on or off the command value it must be taken care that both signal lines are either separated from or connected to the input.

All command values are summated with the correct value and sign before they are connected further[3].

The added ramp generator [4] produces a ramp-like output signal from the jump-like given input signal. The time constant can be set with the potentiometer „t“. The ramp time given refers to a command value jump of 100 % and can be, according to the setting through the selection via jumpers (J5, J6), approximately 1 s or 5 s.

If a command value jump smaller than 100 % is switched to the input of the ramp generator the ramp time shortens appropriately.

External time potentiometer and ramp „Off“

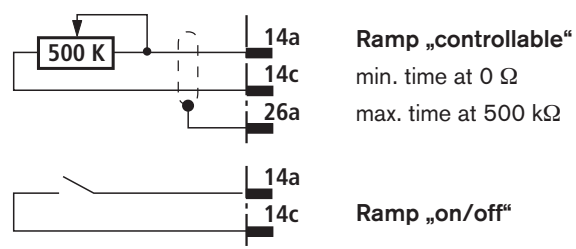

Note:

When using an external time potentiometer the internal potentiometer for the ramp time must be set at maximum. The maximum ramp time decreases because the resistance of the external potentiometer is connected parallel to the internal potentiometer!

Functional Description (Continuation)

By switching the relay K5 or through an external bridge the ramp time is set to its minimum value (approx. 30 ms).

The output signal of the ramp generator [4] runs parallel to the summator [6] and the step function generator [5]. The step function generator produces a polarity-dependent constant step signal with the command value voltages which is added to the output signal of the ramp generator. This step function causes the rapid travelling across the overlapping area of the valve spool.

A positive command value signal at the input of the amplifier controls the output stage for solenoid „B“, a negative command value signal the output stage for solenoid „A“. If the command value signal is smaller than $\pm 1\%$ (step function still ineffective) a pilot current of 20 mA flows through both solenoids. The actual values of the currents through the two solenoids can be measured separately at the test points „I_A“ (solenoid „A“) and „I_B“ (solenoid „B“). Here a current of 800 mA corresponds to a voltage of 800 mV.

LED „H11“ lights up when the system is powered up.

LED „H12“ („Ready for operation“) lights up to indicate trouble-free operation as long as:

- the internal power supply ($\pm 9\text{ V}$) is functioning properly
- there is no short-circuit in the solenoid lines

In the event of a fault, both output stages are immediately de-energized and the signal „Ready for operation“ is cancelled. Once the fault has been cleared, the amplifier card is immediately operable and LED „H12“ lights up again.

1) = Reference potential for the command values 1 to 5 is M0 (measuring zero)

[] = Allocation in block circuit diagram page 4

Block circuit / pin allocation

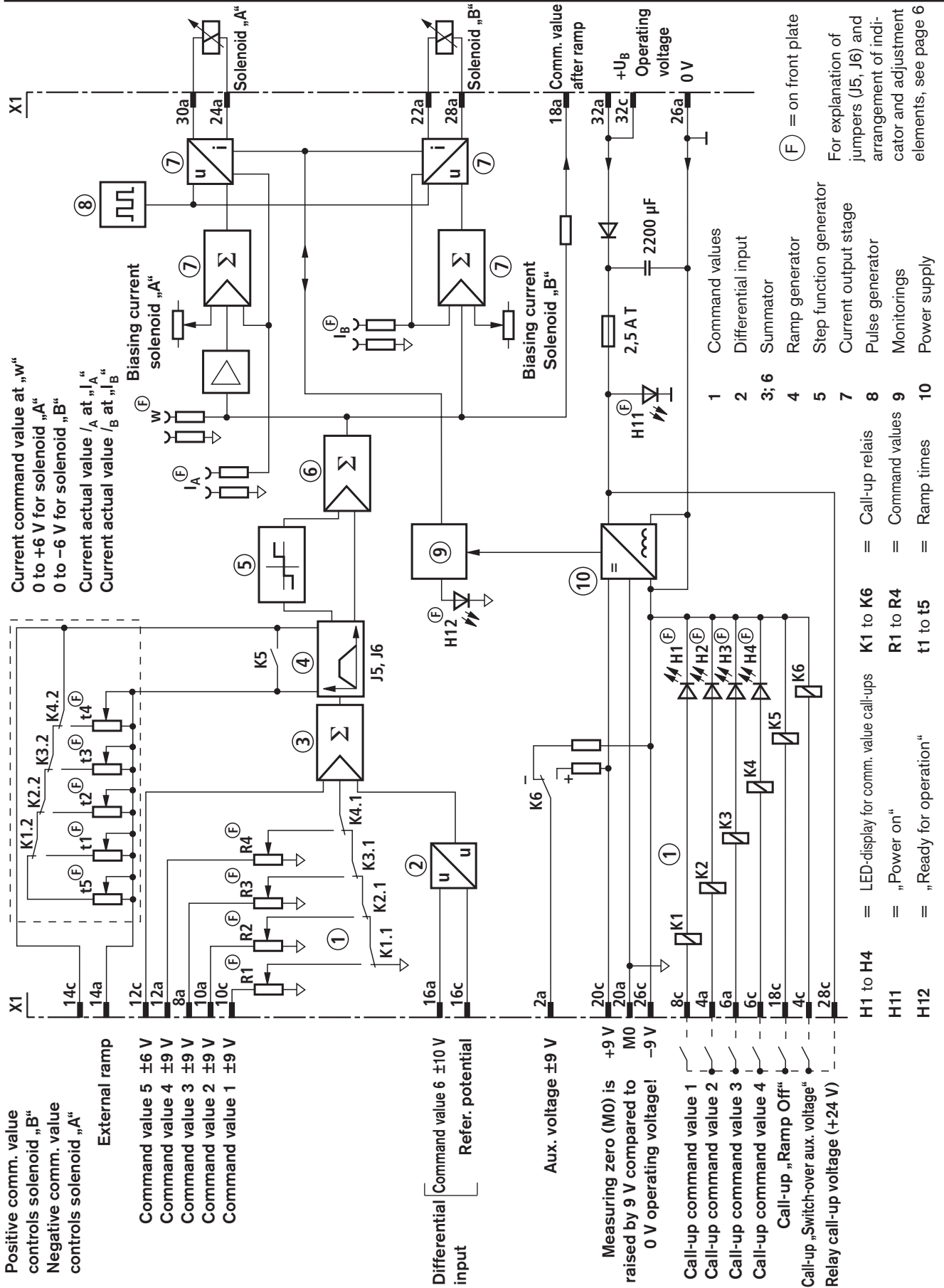

Technical Data (For application outside these parameters please consult us!)

Operating voltage ¹⁾	U_B	24 VDC +60 % -5 %
Operating range:		
– Upper limit value	$u_B(t)_{\max}$	39 V
– Lower limit value	$u_B(t)_{\min}$	22 V
Power consumption	P_S	< 50 VA
Current consumption	I	< 1 A (with loading current)
Fuse	I_S	2.5 A T
Inputs:		
– Command value 1 to 4	U_e	± 9 V (reference potential is M0)
– Command value 5	U_e	± 6 V (reference potential is M0)
– Command value (differential input)	U_e	0 to ± 10 V; $R_e = 100$ k Ω
Ramp time (setting range)	t	30 ms to approx. 1 s or 5 s
Outputs:		
– Output stage		
• Solenoid current/resistance	I_{\max}	800 mA; $R_{(20)} = 19.5$ Ω
• Biasing current	I_V	20 mA ± 25 %
• Pulse frequency	f	170 Hz ± 10 %
– Regulated voltage	U	± 9 V ± 1 %; ± 25 mA externally loadable
– Measuring sockets		
• Current command value „w“	U	± 6 V; $R_i = 5$ k Ω
• Current actual value „I _A “; „I _B “	$U_A; U_B$	0 to 800 mV equivalent 0 to 800 mA
Relay data:		
– Nominal voltage	I	operating voltage U_B
– Threshold voltage	U	16.8 V
– Return voltage	U	2.4 V
– Coil resistance	R	2150 Ω
Type of connection		32-pin terminal strip, DIN 41612, form D
Card dimensions		Euro-card 100 x 160 mm, DIN 41494
Front plate dimensions		
– Height		3 HE (128,4 mm)
– Width soldering side		1 TE (5,08 mm)
– Width component side		7 TE
Permissible operating temperature range	ϑ	0 to 50 $^{\circ}\text{C}$
Storage temperature range	ϑ	-25 to 85 $^{\circ}\text{C}$
Weight	m	0.15 kg

¹⁾ To guarantee the max. solenoid current for the solenoid (19,5 Ω) in the complete solenoid temperature range the operating voltage must be at least 28 VDC!

 **Note!**

For details regarding **environmental simulation test** in the field of EMC (electromagnetic compatibility), climate and mechanical stress, see RE 30304-U (declaration on environmental compatibility).

Output curve

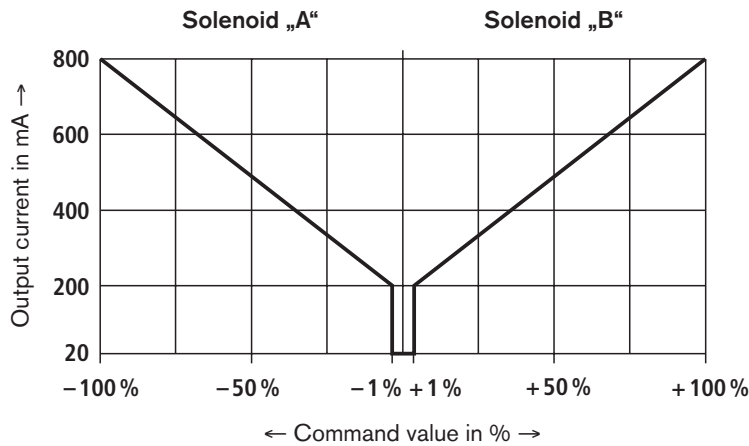

Indicator / Adjustment elements

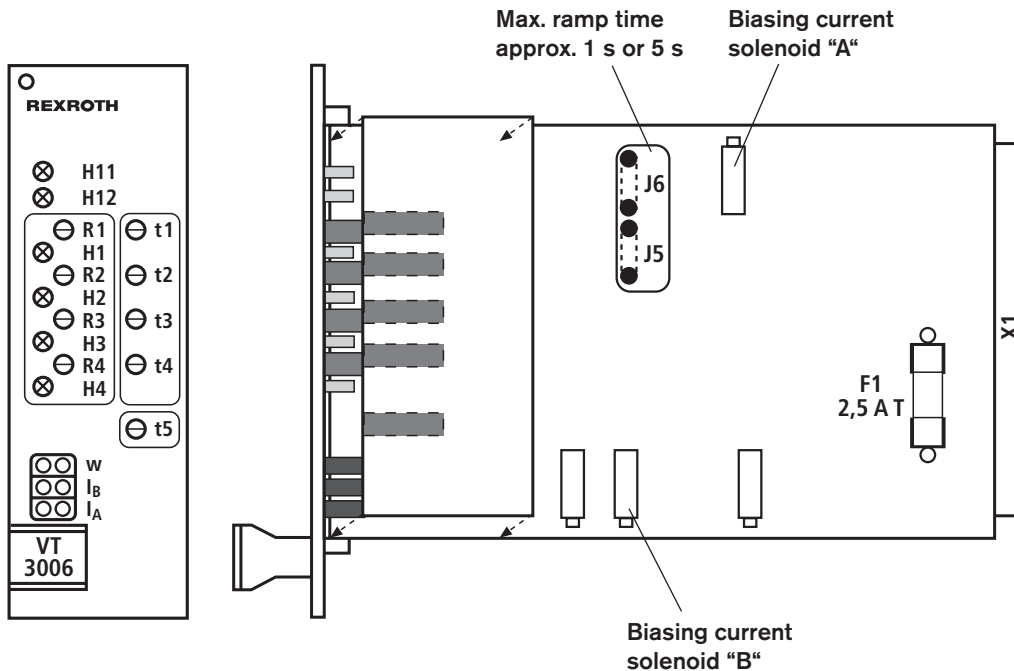

LED-Anzeigen:

- H1 Call-up command value 1
- H2 Call-up command value 2
- H3 Call-up command value 3
- H4 Call-up command value 4
- H11 Operating voltage „power on“ (yellow)
- H12 Indication „Ready for operation“ (green)

Potentiometer:

- R1 Command value 1
- R2 Command value 2
- R3 Command value 3
- R4 Command value 4

t1 to t5 Ramp times

Measuring sockets:

- w Command value solenoid current
- I_A Actual current value solenoid „A“
- I_B Actual current value solenoid „B“

Meaning of the jumpers on the card for the settings

(Label on the back of the front plate)

ramp time	Jx = bridge	jumper plugged in
● 5 s J5 J6	Jx = open	jumper open
○ 1 s J5 J6	● = delivery state	delivery condition

Note:

The loss of unused jumpers can be avoided by plugging these jumpers into only one pin.

Unit dimension (Dimensions in mm)

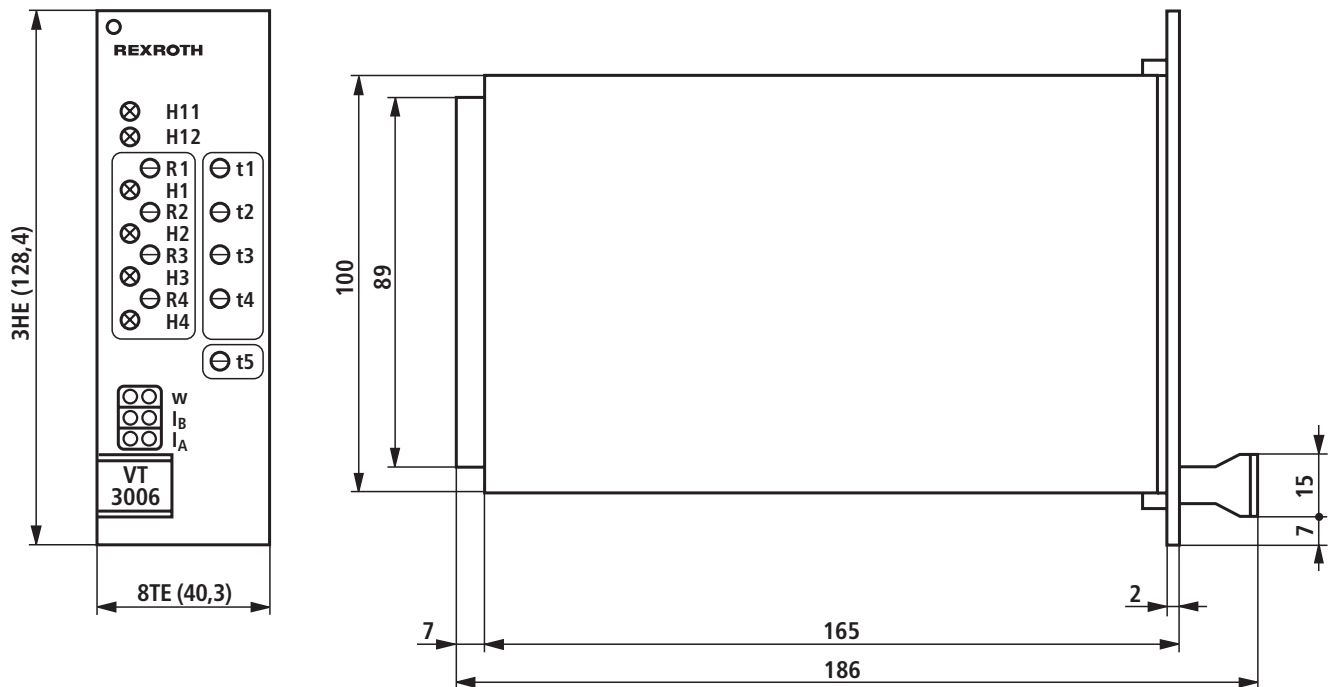

Engineering notes / maintenance instructions / supplementary information

- The amplifier card may only be plugged in or unplugged when switched off!
 - Do not use plugs with free wheel diodes or LED displays when connecting the solenoids!
 - Only carry out measurements on the cards with instruments $R_i > 100 \text{ k}\Omega$!
 - Measuring zero (M0) is raised by +9 V compared to 0 V operating voltage and is **not potentially separated**, i.e. –9 V controlled voltage is **equivalent to** 0 V operating voltage. Therefore do **not** connect measuring zero (M0) to 0 V operating voltage!
 - When switching command values use relays with gold contacts (small voltages, small currents)!
 - When switching card relays only use contacts with a loadability of approx. 40 V, 50 mA!
When controlling externally the control voltage may have a maximum residual ripple of 10 %!
 - Always screen command value lines; connect screen to 0 V operating voltage on the card side, other side remains open (danger of earth loops)!
- Recommendation: Also screen solenoid lines!
 Use cable type LiYCY 1,5 mm² for solenoid lines of up to 50 m in length.
 For longer lengths please consult us!
- Minimum distance to arial lines, radio sources and radar equipment must be at least 1m!
 - Do not lay solenoid and signal lines near power lines!
 - Because of the loading current of the smoothing capacitor on the card pilot fuses must be slow!
 -  **Note!** When using the **differential input both inputs** must always be switched on or off **simultaneously!**

Notes
