

Standard Ball Runner Blocks made of steel

FNS – Flanged, normal, standard height

R1651 ... 2.

Dynamic characteristics

Travel speed: $v_{\max} = 5 \text{ m/s}$







Acceleration: $a_{\max} = 500 \text{ m/s}^2$

(If $F_{\text{comb}} > 2.8 \cdot F_{\text{pr}}$: $a_{\max} = 50 \text{ m/s}^2$)

Note on lubrication

- Pre-lubricated

Further Ball Runner Blocks FNS

- Heavy Duty Ball Runner Blocks made of steel, size 55 and 65  60
- High Precision Ball Runner Blocks made of steel  72
- High-Speed Ball Runner Blocks made of steel  84
- Ball Runner Blocks made of aluminum  94
- Corrosion-resistant Ball Runner Blocks Resist NR  100 Resist NR II  104 Resist CR  108

Note

Can be used on all Ball Guide Rails SNS.

Ordering example

Options:

- Ball Runner Block FNS
- Size 30
- Preload class C1
- Accuracy class H
- With standard seal, without ball chain

Part number: R1651 713 20



Options and part numbers

Size	Ball runner block with size	Preload class			Accuracy class			Seal for ball runner block					
		C0	C1	C2	N	H	P	without ball chain			with ball chain		
								SS	LS ¹⁾	DS	SS	LS ¹⁾	DS
15	R1651 1	9	1		4	3	–	20	21	–	22	23	–
					4	3	2	20	21	–	22	23	–
				2	–	3	2	20	–	–	22	–	–
20	R1651 8	9	1		4	3	–	20	21	–	22	23	–
					4	3	2	20	21	2Z	22	23	2Y
				2	–	3	2	20	–	2Z	22	–	2Y
25	R1651 2	9	1		4	3	–	20	21	–	22	23	–
					4	3	2	20	21	2Z	22	23	2Y
				2	–	3	2	20	–	2Z	22	–	2Y
30	R1651 7	9	1		4	3	–	20	21	–	22	23	–
					4	3	2	20	21	2Z	22	23	2Y
				2	–	3	2	20	–	2Z	22	–	2Y
35	R1651 3	9	1		4	3	–	20	21	–	22	23	–
					4	3	2	20	21	2Z	22	23	2Y
				2	–	3	2	20	–	2Z	22	–	2Y
45	R1651 4	9	1		4	3	–	20	–	–	22	–	–
					4	3	2	20	–	2Z	22	–	2Y
				2	–	3	2	20	–	2Z	22	–	2Y
e.g.	R1651 7		1			3		20					

1) Only with accuracy classes N and H

Preload classes

C0 = without preload
 C1 = preload 2% C
 C2 = preload 8% C

Seals

SS = standard seal
 LS = low-friction seal
 DS = double-lipped seal

Key to table

Gray numbers
 = version/combination not preferred
 (longer delivery times in some cases)

Ball Runner Blocks FNS

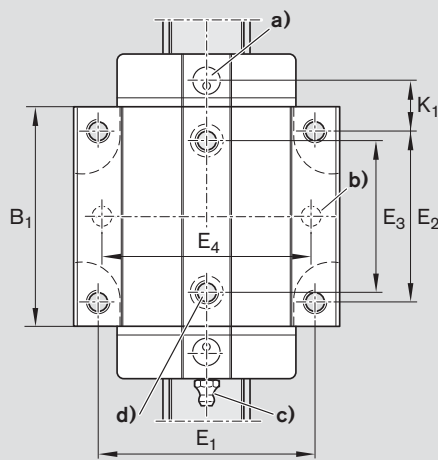
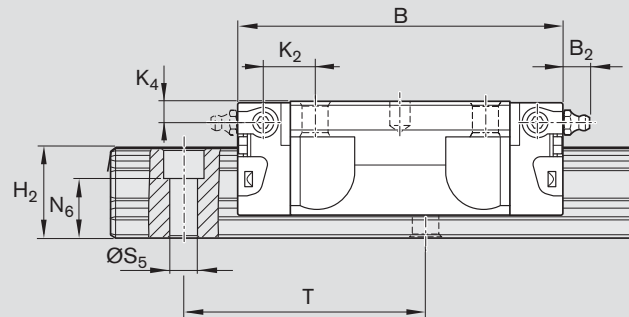
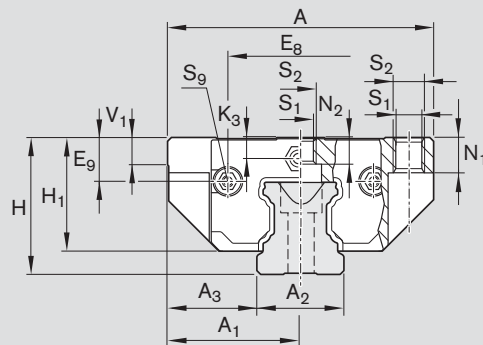

- a) For O-ring
 Size 15: $\text{Ø } 4 \cdot 1.0$ (mm)
 Size 20 - 45: $\text{Ø } 5 \cdot 1.0$ (mm)
 Open lube bore as required (☞ 258).
- b) Recommended position for pin holes (dimensions E_4 ☞ 235).
 Due to manufacturing reasons, there may be rough-drilled holes at the recommended positions. These may be bored open to accommodate the locating pins.
- c) Lube nipple, size 15 - 20:
 Funnel-type lube nipple DIN 3405-A M3x5, $B_2 = 1.6$ mm
 If another lube nipple is used: observe the screw-in depth of 5 mm!
 Lube nipple, size 25 - 45:
 Hydraulic-type lube nipple DIN 71412-B M6x8, $B_2 = 9.5$ mm
 If another lube nipple is used: observe the screw-in depth of 8 mm!
 Lube nipples are provided (unmounted). Connection possible at all sides.
- d) For manufacturing reasons, there may be plugs at these positions. These must be removed before mounting.

Size	Dimensions (mm)																		
	A	A ₁	A ₂	A ₃	B	B ₁	E ₁	E ₂	E ₃	E ₈	E ₉	H	H ₁	H ₂ ¹⁾	H ₂ ²⁾	K ₁	K ₂	K ₃	K ₄
15	47	23.5	15	16.0	58.2	39.2	38	30	26	24.55	6.70	24	19.90	16.30	16.20	8.00	9.6	3.20	3.20
20	63	31.5	20	21.5	75.0	49.6	53	40	35	32.50	7.30	30	25.35	20.75	20.55	11.80	11.8	3.35	3.35
25	70	35.0	23	23.5	86.2	57.8	57	45	40	38.30	11.50	36	29.90	24.45	24.25	12.45	13.6	5.50	5.50
30	90	45.0	28	31.0	97.7	67.4	72	52	44	48.40	14.60	42	35.35	28.55	28.35	14.00	15.7	6.05	6.05
35	100	50.0	34	33.0	110.5	77.0	82	62	52	58.00	17.35	48	40.40	32.15	31.85	14.50	16.0	6.90	6.90
45	120	60.0	45	37.5	137.6	97.0	100	80	60	69.80	20.90	60	50.30	40.15	39.85	17.30	19.3	8.20	8.20

Size	Dimensions (mm)										Weight (kg)	Load capacities ³⁾ (N)		Load moments ³⁾ (Nm)			
	N ₁	N ₂	N ₆ ^{±0.5}	S ₁	S ₂	S ₅	S ₉	T	V ₁	C		C ₀	M _t	M _{t0}	M _L	M _{L0}	
15	5.2	4.40	10.3	4.3	M5	4.4	M2.5x3.5	60	5.0	0.20	7 800	13 500	74	130	40	71	
20	7.7	5.20	13.2	5.3	M6	6.0	M3x5	60	6.0	0.45	18 800	24 400	240	310	130	165	
25	9.3	7.00	15.2	6.7	M8	7.0	M3x5	60	7.5	0.65	22 800	30 400	320	430	180	240	
30	11.0	7.90	17.0	8.5	M10	9.0	M3x5	80	7.0	1.10	31 700	41 300	540	720	290	380	
35	12.0	10.15	20.5	8.5	M10	9.0	M3x5	80	8.0	1.60	41 900	54 000	890	1 160	440	565	
45	15.0	12.40	23.5	10.4	M12	14.0	M4x7	105	10.0	3.00	68 100	85 700	1 830	2 310	890	1 130	

- 1) Dimension H₂ with cover strip
- 2) Dimension H₂ without cover strip
- 3) Load capacities and moments for Ball Runner Block **without** ball chain. Load capacities and moments for Ball Runner Block **with** ball chain ☞ 8. Determination of the dynamic load capacities and moments is based on a travel life of 100,000 m per ISO 14728-1. Often only 50,000 m are actually stipulated. For comparison: Multiply values **C**, **M_t** and **M_L** from the table by 1.26.