

# Analog positioning module

**RE 30050/07.12**  
Replaces: 03.04

1/12

## Type VT-MACAS-...

Component series 1X

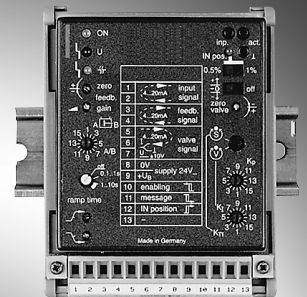

## Table of contents

Contents	Page
Features	1
Ordering code	2
Front plate	3
Block diagram with pin assignment	4
Technical data	5
Function	6
Electrical connection	7 and 8
Adjustment and commissioning	9
Error reactions	10
Velocity controller adjustment	11
Device dimensions	12
Project planning / maintenance instructions / additional information	12

## Features

- Suitable for controlling valves with installed electronics for position and velocity control
- Design: Module for snapping onto carrier rails
- Enable input
- Cable break detection for actual value cable
- Interfaces short-circuit-proof
- Test points on front plate
- Compensation step that can be switched off
- Position: PT1 control
- Velocity control possible in connection with tachometer (speed indicator): PI control
- Area adjustment cylinder

### Notice:

The photo is an example configuration.  
The delivered product differs from the figure.

## Ordering code

VT- M A C A S - 500 - 1X / V0 /

Hydraulic component

Axis control

= A

Type

Controller

= C

Control

Analog

= A

Function

Position control

= S

without =

I =

V0 =

1X =

500 =

Option

Marking

Variant with voltage input

Variant with current input

Customer version

Catalog version

Component series 10 to 19

(10 to 19: Unchanged technical data and pin assignment)

Serial number for types

Standard variant without valve amplifier function

## Preferred types

Amplifier type	Material number
VT-MACAS-500-10/V0	0811405139
VT-MACAS-500-10/V0/I	0811405140

# Front plate

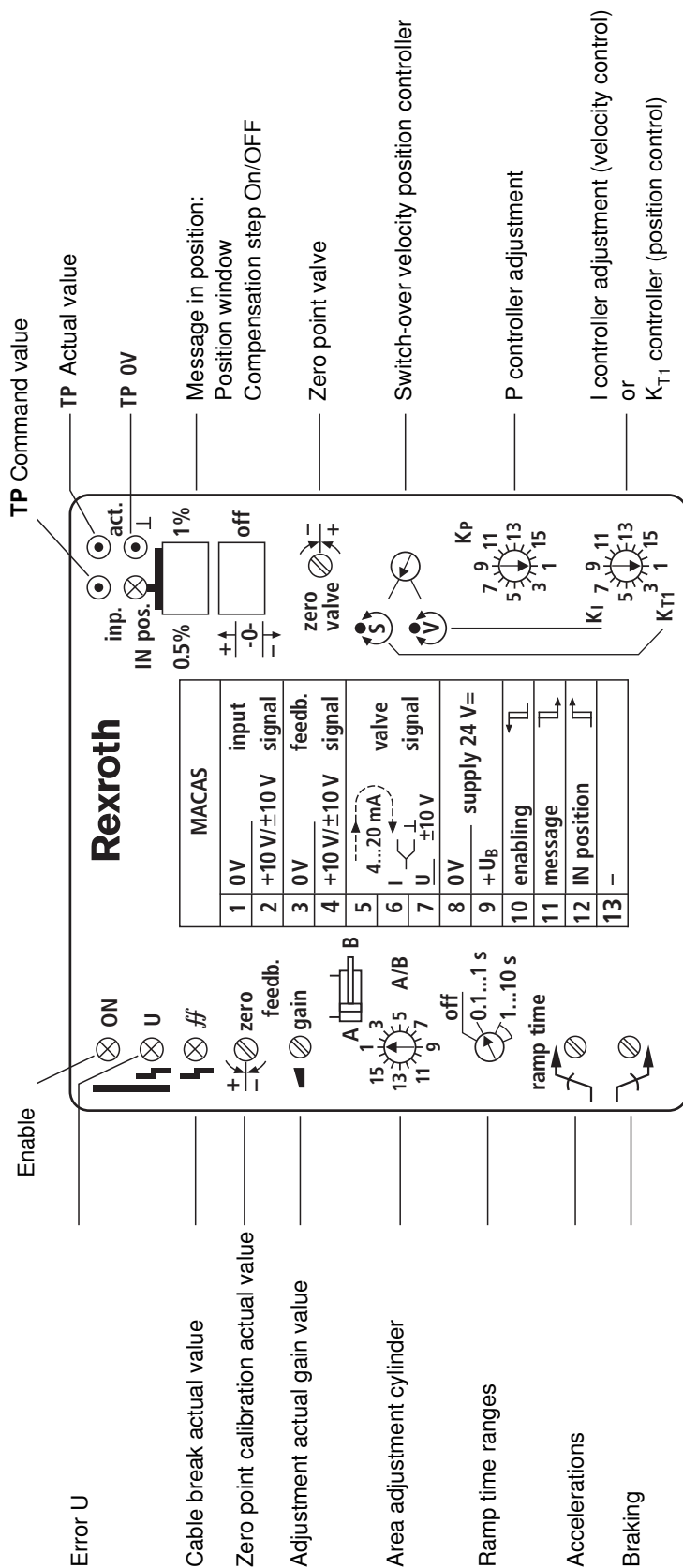

### Block diagram with pin assignment

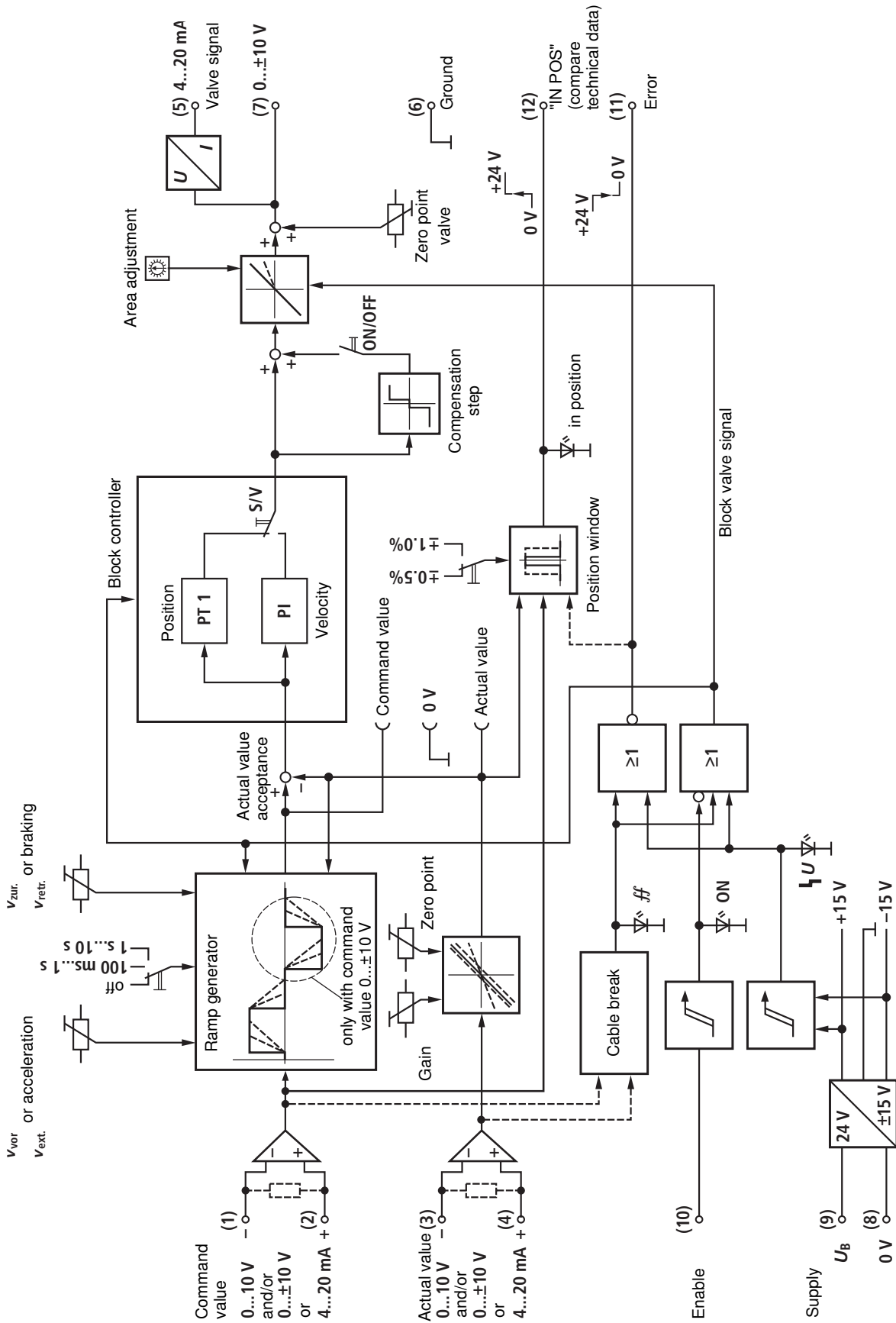

**Technical data** (For applications outside these parameters, please consult us!)

Supply voltage (8), (9)		Nominal 24 V = Battery voltage 21...40 V, Rectified alternating voltage $U_{\text{eff}} = 21...28$ V (one-phase, full-wave rectifier)
Current consumption, max.	mA	200
Signal input (1), (2)	VT-MACAS-500-10/V0	$U_{\text{command}}: \pm 10$ V, differential amplifier $R_i = 100$ k $\Omega$
	VT-MACAS-500-10/V0/I	$I_{\text{command}}: 4...20$ mA $R_{\text{sh}} = 200$ $\Omega$
Actual value signal (3), (4)	VT-MACAS-500-10/V0	$U_{\text{actual}}: \pm 10$ V, differential amplifier $R_i = 100$ k $\Omega$
	VT-MACAS-500-10/V0/I	$I_{\text{actual}}: 4...20$ mA $R_{\text{sh}} = 200$ $\Omega$
Valve signal (5), (6, (7))		$U_V = \pm 10$ V (max. 10 mA) or $I_V = 4...20$ mA (middle 12 mA)
Compensation step		Can be switched off; effective in a range of $\pm 4\%$
Enable signal (10)	V=	8.5...40
Error message (11)		No error: $24 V_{\text{nom}} (U_B)$ max. 50 mA Error: $< 2$ V
IN POS message (12)		IN POS: $24 V_{\text{nom}} (U_B)$ max. 50 mA Not IN POS: $< 2$ V
Ramp ranges		I: 0.1 ... 1 s II: 1 ... 10 s
Area adjustment $A_K : A_R$		Min. 1:1; max. 1:4
Actual value adjustment		Zero point: $-5...10\%$ Gain: 50...110%
Controller type		Position: PT <sub>1</sub> Velocity: PI
Zero point valve	%	$\pm 5$
Special features		– Switchable from position to velocity control – Switchable position window – Test points on front plate – Interfaces short-circuit-proof
Format/design	mm	(86 x 110 x 95.5) / module
Mounting		Top hat rail TH35-7,5 or G rail G32 according to EN 60715
Connection		Connectors + terminals
Ambient temperature	$^{\circ}\text{C}$	0...+70
Storage temperature range	$^{\circ}\text{C}$	$-20...+70$
Weight	m	0.38 kg

## Function

### Applications

By means of this controller module, simple position or velocity controls can be represented in connection with Bosch Rexroth servo cylinders with analog position measurement systems (potentiometer). As the entire signal processing is analog and the module is only equipped with the necessary features for the set-up of controls, the costs for the drive can be kept low. There is moreover the particularity that the module can be internally switched to velocity control (front plate) and one version is in each case offered for voltage interface and current interface, referring to the command and actual values.

### Position control

Command and actual value of the position are compared and the deviation is forwarded to the valve amplifier. In case of an abrupt change of the input signal, the system will react with maximum dynamics. The times for accelerating or braking a load are either limited by the available power or the system gain. With a ramp function as input value, the load is moved with a constant velocity.

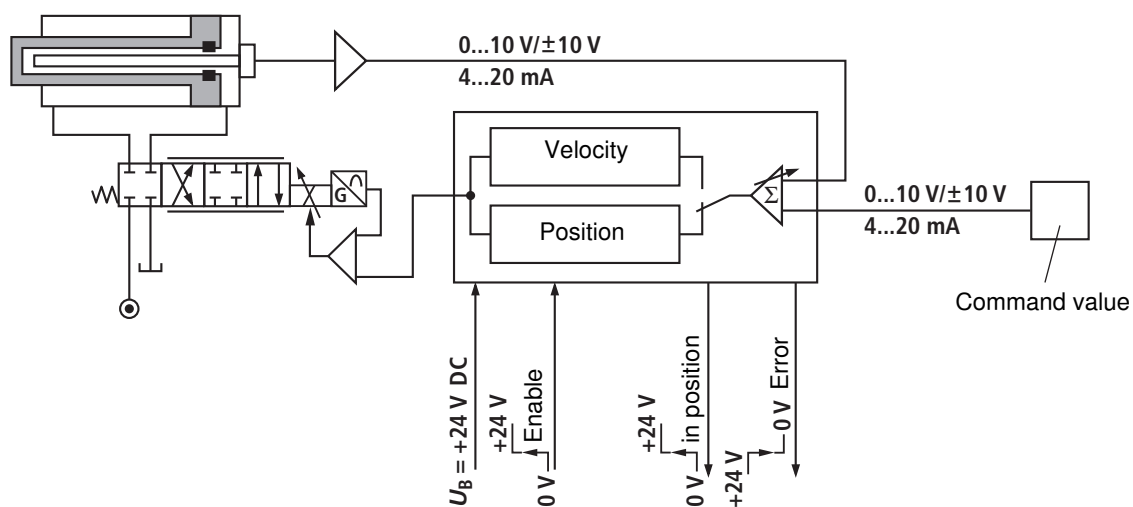

### Velocity control\*

Command and actual value of the velocity are compared and the deviation is forwarded to the valve amplifier. The signal is amplified by integration so that even smallest errors are compensated.

With a ramp function as input signal, there is a gradual acceleration and/or deceleration with a constant value.

\* Only possible with tachometer (speed indicator).

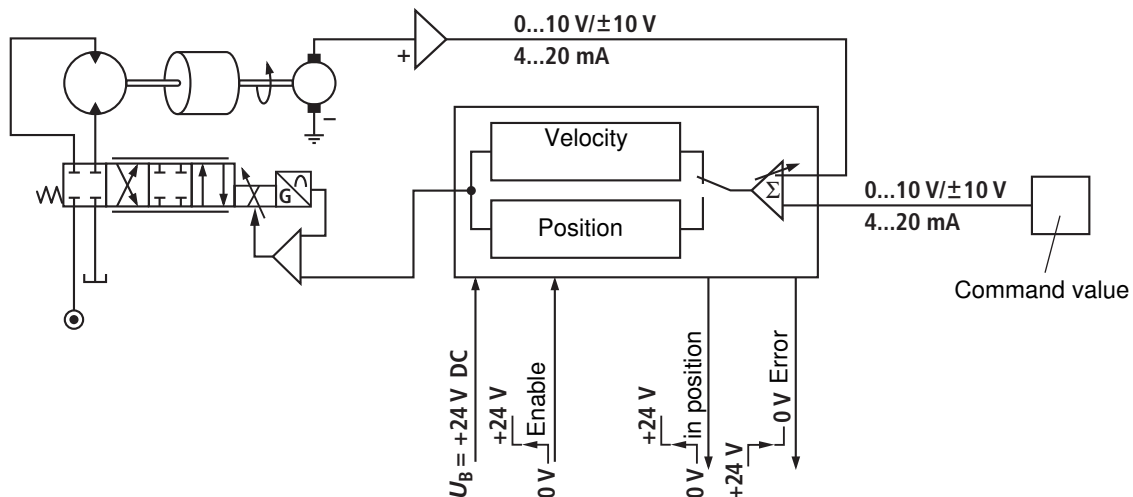

## Electrical connection

### Wiring diagram AVPC-V

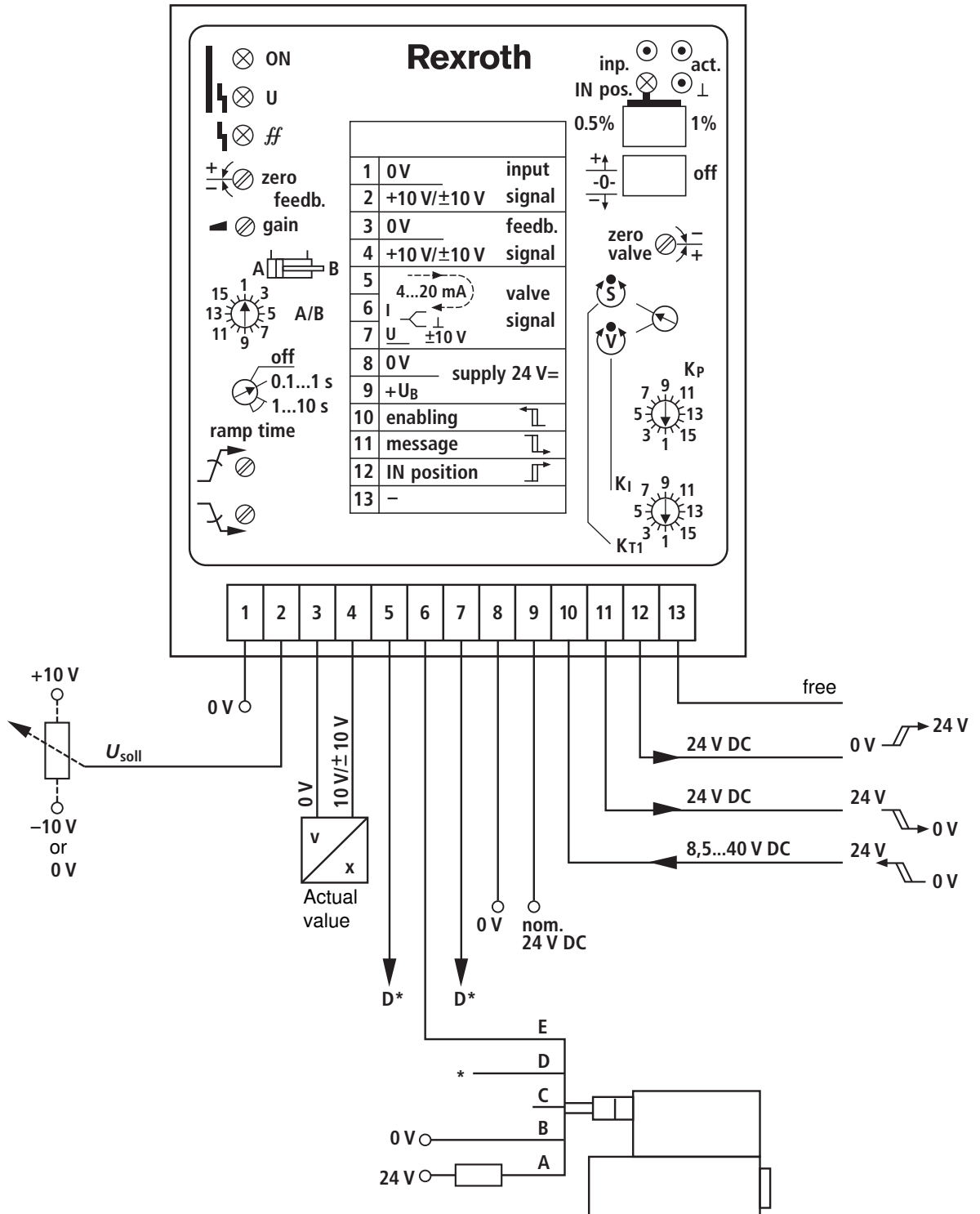

D\* valve signal for valve with voltage or current interface

## Electrical connection

### Wiring diagram AVPC-mA

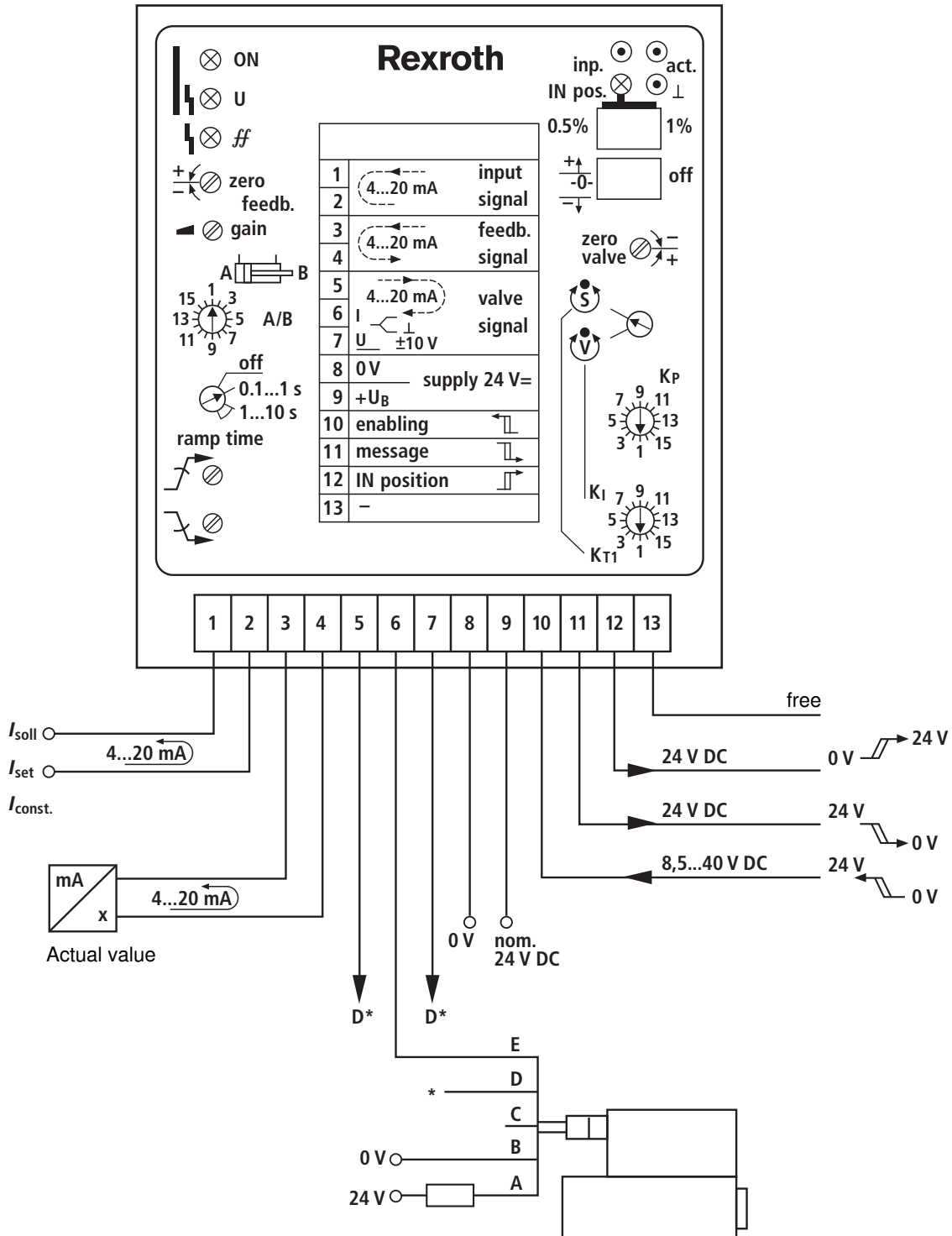

D\* valve signal for valve with voltage or current interface



## Adjustment and commissioning

The entire adjustment of the module is carried out at the front plate with operating pressure.

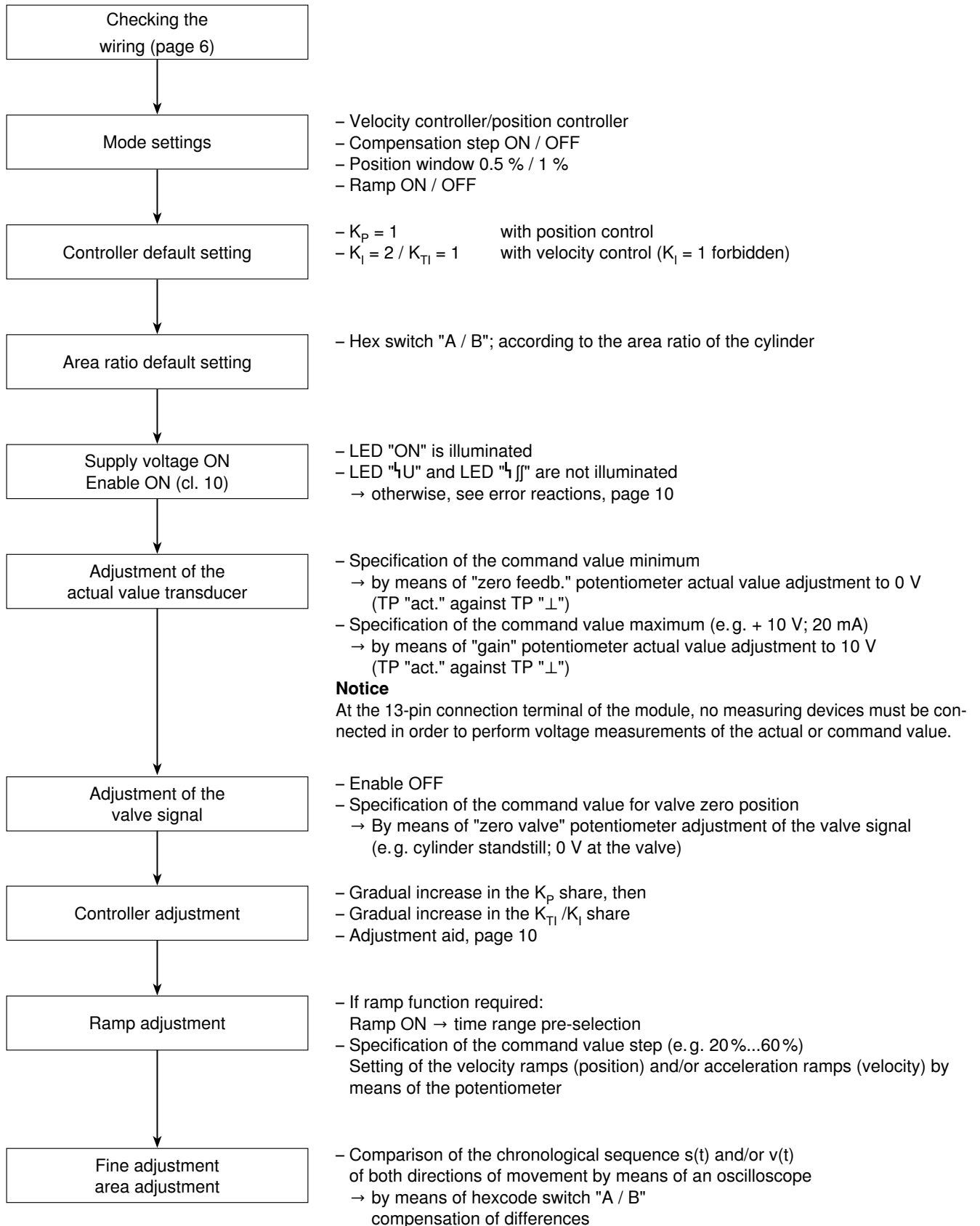

## Error reactions

- ↳ U: Tripping if the value falls below the minimum internal supply voltage  
 ⇒ Valve signal 0 V and/or 12 mA;  
 ⇒ Message LED "U" and (11)

The error is stored.  
**Deletion of the error** by switching the enable signal or the supply voltage off and on again.

Possible causes: External supply voltage too low (< 16 V) or internal error (→ repair).

- ↳ JJ: **Tripping** if the actual value or command value lines break  
 ⇒ Valve signal 0 V and/or 12 mA;  
 ⇒ Message LED "JJ" and (9)

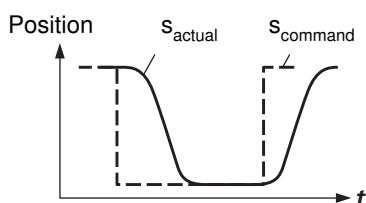
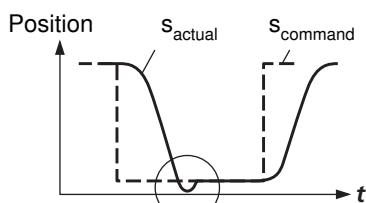
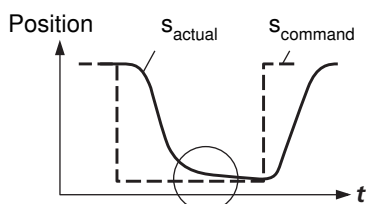
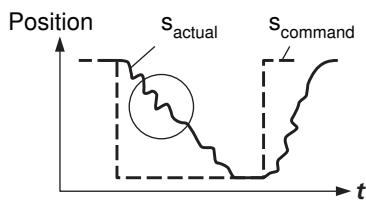
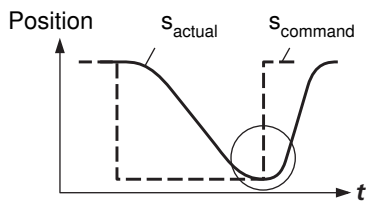
	<p>Ideal development (without command value ramps)</p>
	<p>"Overshooting", P gain too high, → rotate switch <math>K_p</math> against 1</p>
	<p>"Creeping into the position", P gain too low, → rotate switch <math>K_p</math> against 16</p>
	<p>"Vibrations", time constant too small, → rotate switch <math>K_{T1}</math> against 16</p>
	<p>"Area ratio wrong"; set symmetric motion sequence by means of switch A/B</p>

## Velocity controller adjustment

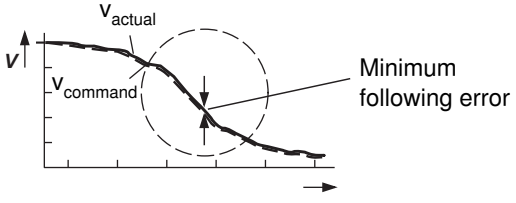
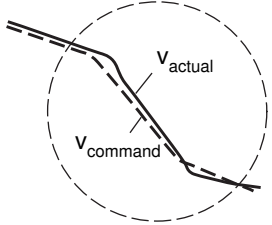
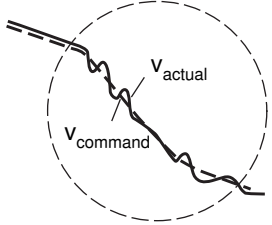
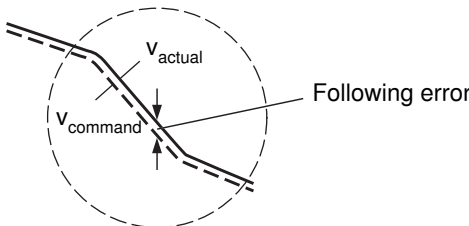
 <p>Minimum following error</p>	<p>Ideal development (without command value ramps)</p>
	<p>P gain too small, → rotate switch <math>K_P</math> against 16</p>
	<p>P gain too large, → rotate switch <math>K_P</math> against 1</p>
 <p>Following error</p>	<p>P gain correct, however following error too large, minimization of the following error by means of the I controller → rotate switch <math>K_I</math> until the min. following error is reached</p>

## Device dimensions (dimensions in mm)

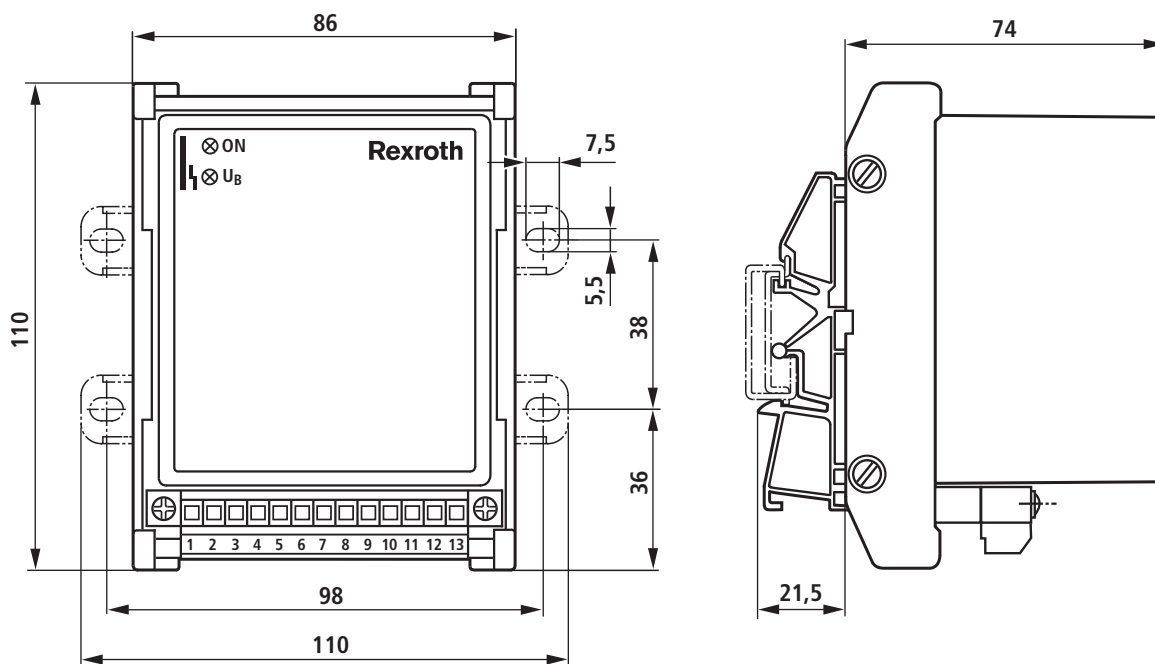

Wall mounting

(86 x 110 x 95.5) mm

Carrier rail assembly (snap-in)

## Project planning / maintenance instructions / additional information

- The distance to aerial lines, radios and radar systems must be sufficient (> 1 m).
- Do not lay solenoid and signal lines near power cables.
- For signal lines and solenoid conductors, we recommend using shielded cables.  
The cable shield must be connected to the control cabinet extensively and as short as possible.
- The valve solenoid must not be connected to free-wheeling diodes or other protection circuits.