

Contents

Design Features / Specifications	B158
Ordering Information.....	B159
Dimensions, Mounting Kits & Accessories	B160
Service Kits	B161

B

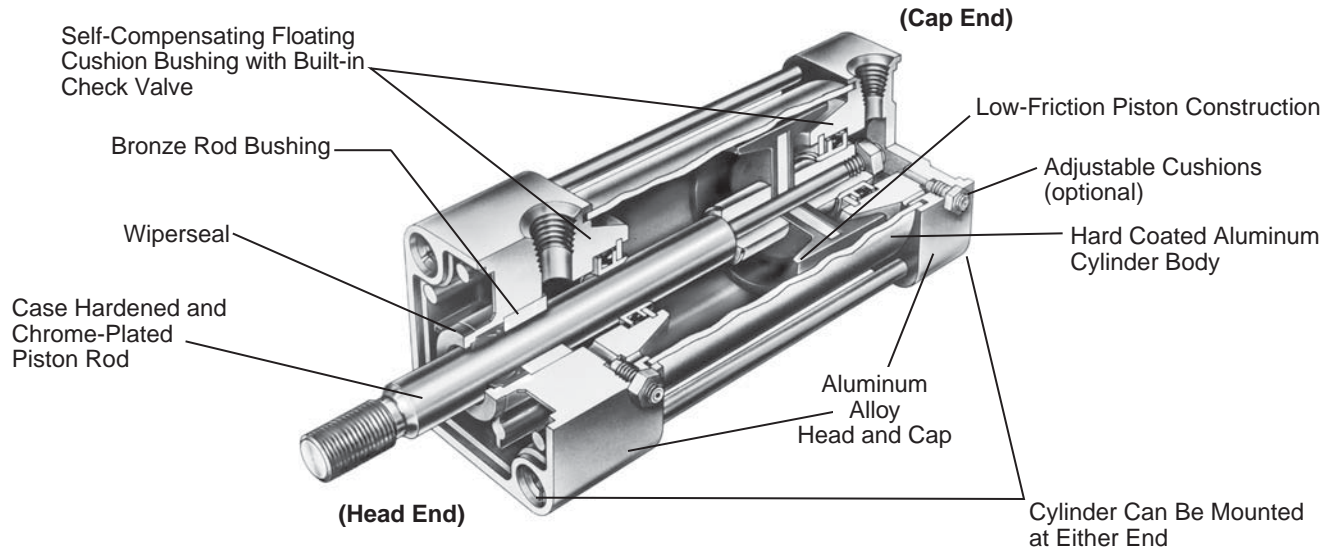

Parker C Series Cylinders

Parker C Series cylinders are designed for the budget conscious user who demands a high-quality cylinder. Advanced manufacturing processes provide a cylinder that ensures long-term performance at an affordable price.

Innovative Design

C Series cylinders incorporate many innovative design features, such as:

- “Wiperseal” rod seal minimizes the possibility of leakage, while keeping contamination out.
- Oil impregnated, bronze rod bushing provides maximum bearing area and a non-abrasive surface for long service life.
- Synthetic rubber coated piston is designed to compensate for wear, eliminating metal-to-metal contact.
- Fully adjustable, floating cushions offer an efficient means of decelerating heavy loads.
- Modular design offers flexibility by providing three different mounting options with the basic cylinder. In addition to this, four different mounting kits can be bolted on quickly and easily.

In line with our policy of continuing product improvements, specifications in this catalog are subject to change.

Specifications

Bore Sizes: 1-1/4", 1-3/4", 2-1/2", 3-5/8", and 4-1/2"

Strokes: Available in any practical stroke length, with a maximum stroke of 20" standard. For longer stroke lengths, consult the Actuator Division.

Operating Pressure: 200 PSI Air Maximum

Operating Temperature: -4° to +165°F for optimal service life. C Series cylinders can be operated up to 200°F with reduced service life.

Spring Extend & Spring Return Models: Can be supplied upon request. LB and LD dimensions may increase in length. For specific dimensional information on spring return or spring extend cylinders, consult the Actuator Division.

Force Data: To determine force, multiply your air pressure by these area figures:

Bore	Cap End Major Area	Head End Minor Area
1-1/4"	1.23 sq. in.	1.03 sq. in.
1-3/4"	2.40 sq. in.	2.10 sq. in.
2-1/2"	4.91 sq. in.	4.60 sq. in.
3-5/8"	10.32 sq. in.	9.54 sq. in.
4-1/2"	15.90 sq. in.	15.12 sq. in.

Prelubrication

C Series air cylinders are factory pre-lubricated. Parker Lube-A-Cyl is applied to cylinder bore, piston rod and seals. Lube-A-Cyl is an extreme pressure lubricant which adheres to the surfaces and for medium duty service, additional lubrication is not necessary.

How to Order Parker C Series Cylinders

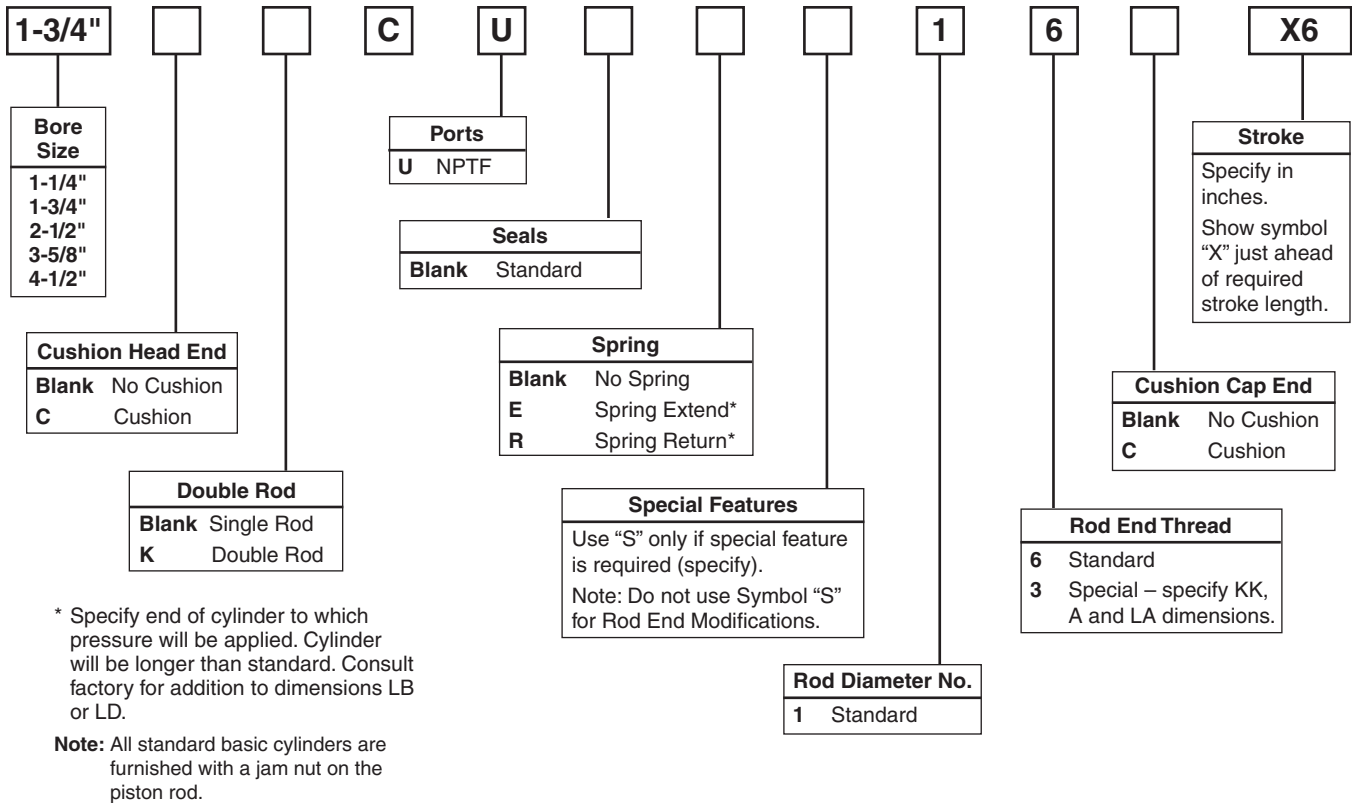

Specify the following:

- Basic Model Number
- Mounting Kits (if required) – specify kit numbers
- Rod End Accessory Kits (if required) – specify kit number
- Quantities
- Desired Delivery Date

Mounting Kit Numbers

Bore Size	Part Numbers			
	End Lugs Head & Cap Set of 4	Rectangular Flange Head or Cap End	Detachable Clevis* (Cap End)	Detachable Eye (Cap End)
1-1/4"	L045010000	L045060000	L045110000	L045160000
1-3/4"	L045020000	L045070000	L045120000	L045170000
2-1/2"	L045030000	L045080000	L045130000	L045180000
3-5/8"	L045040000	L045090000	L045140000	L045190000
4-1/2"	L045050000	L045100000	L045150000	L045200000

* Furnished complete with pivot pin and cotter pin.
 Mounting Kits include fasteners for attaching to basic cylinders.

Rod End Accessory Kit Numbers

Bore Size	Part Numbers		
	Long Clevis* (Female)	Short Clevis* (Female)	Rod Button
1-1/4"	L045210000	L045230000	18153
1-3/4"	L045220000	L045240000	18154
2-1/2"	L045220000	L045240000	18154
3-5/8"	–	L045250000	74718
4-1/2"	–	L045250000	74718

* Furnished complete with pivot pin and cotter pin.

B

Symbol	Bore Size				
	1-1/4"	1-3/4"	2-1/2"	3-5/8"	4-1/2"
A	1	1	1	1-5/8	1-5/8
B	$0.999^{+0.000}_{-0.005}$	1.124	1.124	1.749	1.749
BD	7/8	7/8	7/8	7/8	1-7/8
BE	6	6	6	7-7/8	7-7/8
BF	5/8	5/8	5/8	1-1/4	1-1/4
BG	1-1/2	1-1/2	1-1/2	2-1/2	2-1/2
BH	7/8	7/8	7/8	1-3/8	1-3/8
BJ	3/4	3/4	3/4	1-1/8	1-1/8
C	9/16	5/8	5/8	1	1
CB	1/4	1/2	1/2	3/4	3/4
CD	3/8	1/2	1/2	3/4	3/4
CE	1-1/16	1-3/16	1-3/16	2-1/4	2-1/4
CH	1/4	9/32	9/32	-	-
CJ	1/2	9/16	9/16	-	-
CK	1-39/64	1-37/64	1-37/64	-	-
CM	23/32	13/16	13/16	-	-
CN	2-7/8	3	3	-	-
CP	7/16	1/2	1/2	-	-
CQ	13/16	15/16	15/16	-	-
CR	1/4	5/16	5/16	5/8	5/8
CW	1/4	5/16	5/16	7/16	7/16
E	1-3/4	2-1/4	2-7/8	4	5
EA	1/4-28	5/16-24	5/16-24	3/8-24	1/2-20
EB	9/32	3/8	3/8	7/16	9/16
EE	1/4	1/4	1/4	1/2	1/2
EL	7/16	7/16	3/8	11/16	3/4
EO	5/16	5/16	3/8	7/16	1/2
ET	9/16	5/8	11/16	1	1-1/8
EW	1/4	1/2	1/2	3/4	3/4
F	3/8	1/2	1/2	3/4	3/4
FB	9/32	3/8	3/8	7/16	9/16
FL	1	1-1/4	1-1/2	1-7/8	2-1/4
G	1-3/4	1-3/4	1-7/16	2	1-29/32
J	1-1/8	1-1/8	1-1/16	1-1/2	1-13/32
KK	7/16-20	1/2-20	1/2-20	7/8-14	7/8-14
L	9/16	5/8	5/8	1-1/8	1-1/8
LA	1-9/16	1-5/8	1-5/8	2-5/8	2-5/8
LB	3-13/16	3-31/32	3-21/32	4-29/32	4-15/16
LD	4-7/16	4-19/32	4-1/32	5-13/32	5-7/16
MM	1/2	5/8	5/8	1	1
MR	1/2	1/2	9/16	7/8	1
NT	10-24 x 1/4	5/16-18 x 3/8	5/16-18 x 1/2	3/8-16 x 1	5/8-11 x 1-1/4
P	2-7/16	2-19/32	2-5/32	2-25/32	2-7/8
R	1.18	1.62	2.18	3.00	3.87
SL	1-1/8	1-1/8	15/16	1-5/16	1-9/32
SN	2-3/16	2-11/32	2-5/32	2-25/32	2-7/8
TE	1.18	1.62	2.18	3.00	3.87
TF	2-3/8	3	3-9/16	4-7/8	6-1/8
TN	5/8	11/16	1-1/4	1-3/4	2-1/4
UF	2-7/8	3-5/8	4-1/8	5-5/8	7-1/8
UL	1-3/4	2-1/4	2-7/8	4	5
V	1/8	1/8	1/8	3/16	3/16
W	3/16	1/8	1/8	1/4	1/4
XT	1-11/16	1-3/4	1-9/16	2-5/16	2-9/32
Y	1-9/16	1-5/8	1-9/16	2-5/16	2-9/32
ZB	4-3/8	4-19/32	4-9/32	5-29/32	5-15/16
ZL	5	5-7/32	4-21/32	6-13/32	6-7/16
ZM	5-9/16	5-27/32	5-9/32	7-13/32	7-7/16

Single Rod End Cylinders

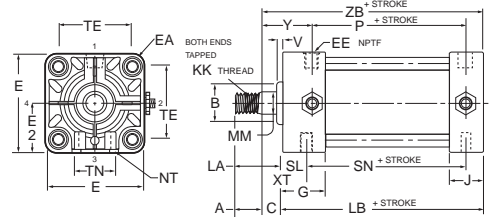

Double Rod End Cylinders

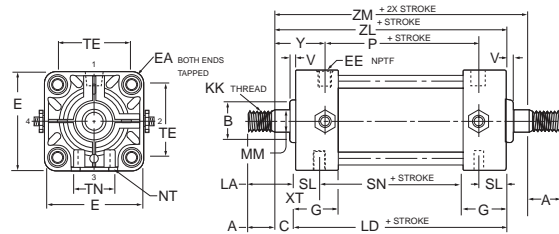

Mounting Kits

Mountings are available in packaged kits. Detachable Clevis is furnished with pivot and cotter pins. See Ordering Information page for Kit Numbers.

End Lugs (Head and Cap)

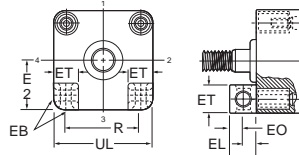

Detachable Clevis (Cap End)

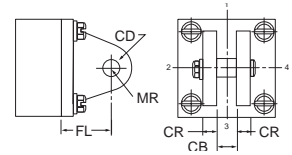

Rectangular Flange (Head End)

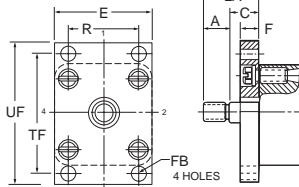

Detachable Eye (Cap End)

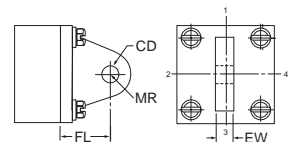

Detachable Clevis and Detachable Eye are mating parts that provide for mounting of cylinder to a structural member.

Rod End Accessories

Accessories are available packaged separately. Clevis furnished complete with pivot and cotter pins. See Ordering Information page for Kit Numbers.

Rod Button

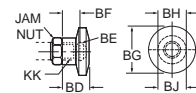

Short Clevis (Female)

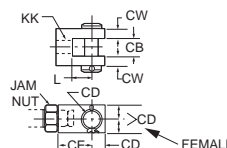

Long Clevis (Female)

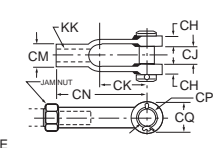

Bore Size					
	1-1/4"	1-3/4"	2-1/2"	3-5/8"	4-1/2"
Complete Cylinder Seal Kit	SK1200C051	SK1700C061	SK2500C061	SK3600C101	SK4500C101
Cushion Kit - Head End	CH1200C001	CH1700C001	CH2500C001	CC3600C001	CC4500C001
Cushion Kit - Head End	CC1200C001	CC1700C001	CC2500C001	CC3600C001	CC4500C001

B

3MAJ/4MA

3MAJ/4MAJ

ACVB
Option

LPSO
Option

4MNR

S

C